

THIS DRAWING IS UNPUBLISHED. RELEASED FOR PUBLICATION
 © COPYRIGHT BY TYCO ELECTRONICS CORPORATION. ALL RIGHTS RESERVED.

LOC	DIST	REVISIONS			
P	LTR	DESCRIPTION	DATE	DWN	APVD
AF	50	G	REVISED PER 0G3A-0691-02	19DEC02	MF GP

- 1 CONTINUOUS STRIP ON REELS WITH TERMINALS LOCATED ON .350 CENTERS.
- △2 P/N 61769-3 TO BE PACKAGED ON PLASTIC REELS, 25,000 PER REEL.
- △3 CRIMP WIDTH: .090 F TYPE
 CRIMP HEIGHT: (±.002) = (TOTAL CMA + 8300) / 145,800
 FOR APPLICATOR INFORMATION CALL: 1-800-722-1111
 FOR PRODUCT INFORMATION CALL: 1-800-522-6752
- △4 PRELIMINARY - NOT FOR PRODUCTION.

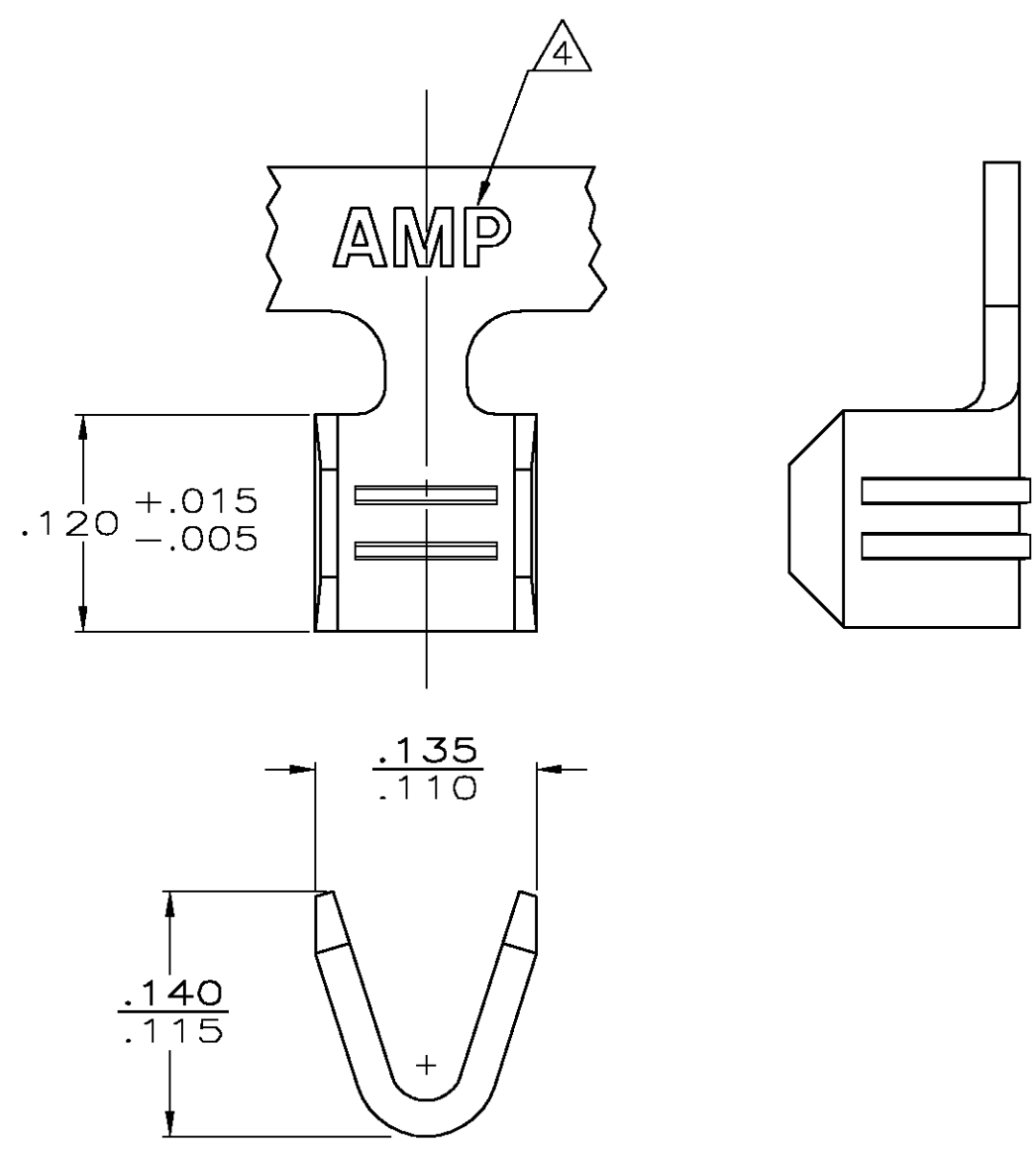

WIRE SIZE CMA	FINISH	MATERIAL	PART NUMBER
1200-2600	-	.020 STAINLESS STEEL	△4 61769-4
	-	.020 BRASS	61769-3
	NICKEL	.020 STEEL	61769-2
	-	.020 BRASS	61769-1

THIS DRAWING IS A CONTROLLED DOCUMENT.		DWN 19DEC2002 MICHAEL S. FEHER	tyco Tyco Electronics Corporation	
DIMENSIONS: INCHES		CHK 19DEC2002 GARY PORTA	Electronics Harrisburg, PA 17105-3608	
TOLERANCES UNLESS OTHERWISE SPECIFIED: 0 PLC ± - 1 PLC ± - 2 PLC ± - 3 PLC ± .010 4 PLC ± - ANGLES ± -		APVD 19DEC2002 GARY PORTA	NAME -	
MATERIAL SEE TABLE		PRODUCT SPEC -	SPLICE -	
FINISH SEE TABLE		APPLICATION SPEC -	SIZE A3	RESTRICTED TO -
		WEIGHT -	CAGE CODE 00779	DRAWING NO 61769
		CUSTOMER DRAWING	SCALE 10:1	SHEET 1 OF 1 REV G